



Evaluation Report CCMC 13507-R

MASTERFORMAT: 06 17 10
Issued: 2010-10-27
Revised: 2011-01-05
Re-evaluation due: 2013-10-27

Murphy LVL

1. Opinion

It is the opinion of the Canadian Construction Materials Centre (CCMC) that “Murphy LVL” when used as structural composite lumber (SCL) in accordance with the conditions and limitations stated in Section 3 of this Report, complies with the National Building Code 2005:

- Clause 1.2.1.1.(1)(a), Division A, using the following acceptable solutions from Division B:
 - Sentence 4.3.1.1.(1) Design Basis for Wood (CAN/CSA-O86-01, "Engineering Design in Wood," for SCL qualification)
- Clause 1.2.1.1.(1)(b), Division A, as an alternative solution that achieves at least the minimum level of performance required by Division B in the areas defined by the objectives and functional statements attributed to the following applicable acceptable solutions:
 - Sentence 9.23.4.2.(3) Spans for Joists, Rafters and Beams

This opinion is based on CCMC's evaluation of the technical evidence in Section 4.1 provided by the Report Holder.

Ruling No. 10-21-258 (13507-R) authorizing the use of this product in Ontario, subject to the terms and conditions contained in the Ruling, was made by the Minister of Municipal Affairs and Housing on 2010-12-30 pursuant to s.29 of the Building Code Act, 1992 (see Ruling for terms and conditions). This Ruling is subject to periodic revisions and updates.

2. Description

The product is manufactured by laminating veneer sheets of Douglas Fir coated with an exterior-type adhesive conforming to CSA O112.6-M1977(R2006), “Phenol and Phenol Resorcinol Resin Adhesives for Wood (High Temperature Curing),” in specific lay-up patterns, which are fed into a continuous press with the grain of the veneer oriented parallel to the length of the member. The lay-up patterns and adhesives used are as specified in the Murphy Company, Engineered Wood Division (EWD) Manufacturing Standard.

The product is available in thicknesses from 35 mm to 89 mm, in widths ranging from 89 mm to 610 mm, and in lengths up to 24 m.

The manufacturing quality assurance program and records are verified by APA-The Engineered Wood Association as part of the product certification.

Figure 1 illustrates the veneer orientation of “Murphy LVL.”

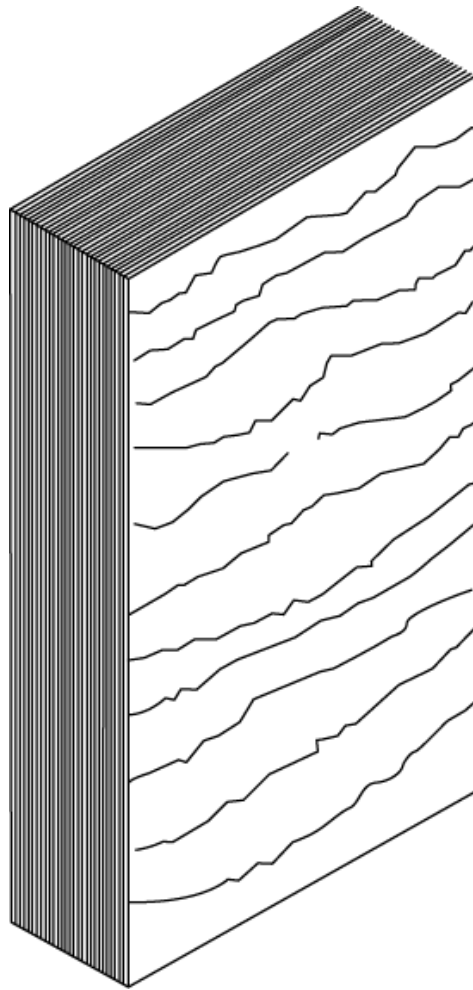

Figure 1. Typical Laminated Veneer Lumber (LVL)

3. Conditions and Limitations

CCMC's compliance opinion in Section 1 is bound by the "Murphy LVL" being used in accordance with the conditions and limitations set out below.

- As with all SCL, this product is intended for dry service applications only.⁽¹⁾

(1) All lumber, wood-based panels and proprietary engineered wood products are intended for dry service conditions. "Dry service" is defined as the in-service environment under which the equilibrium moisture content (MC) of lumber is 15% or less over a year and does not exceed 19% at any time. Wood contained within the interior of dry, heated or unheated buildings has generally been found to have a MC between 6% and 14% depending on season and location. During construction, all wood-based products should be protected from the weather to ensure that the 19% MC is not exceeded in accordance with Article 9.3.2.5., Moisture Content, of Division B of the NBC 2005.

- The product is intended for use in construction as an alternative material to lumber. Proprietary design values presented for the product are to be used by professional engineers for design in accordance with CAN/CSA-O86, "Engineering Design in Wood," for structural applications such as beams, headers, joists, rafters, and columns as intended by the product manufacturer. The specific application must be qualified through specific testing and validated by the manufacturer. Applications such as I-joist flanges, studs and metal-plated truss chords are beyond the scope of this evaluation.

- The pre-engineered tables in the literature outlined below have been provided to CCMC by the Murphy Company to demonstrate compliance to Part 9 for acceptance by the local authority having jurisdiction (AHJ):

i) Murphy Company's Pre-engineered Tables⁽²⁾

When the product is used to support uniform loads only, the installation must be in accordance with the tables and installation details published by the Murphy Company in the document entitled "Murphy LVL Limit States Design Guide (2.0 E-LVL - 1.5 E-LVL)," dated September 2010.

For applications falling within the scope of the Murphy Company's above-noted document, the product must be installed in accordance with the installation guidelines contained therein. Applications outside the scope of these installation guidelines require engineering on a case-by-case basis.

(2) The pre-engineered tables present the pre-engineered factored resistance of the beam. The AHJ may require further engineering to determine the factored load in accordance with Part 4 of Division B of the NBC 2005.

ii) Murphy Company's Installation Details

Murphy Company's pre-engineered details within the document outlined in (i) above are limited in scope to building designs where the anticipated loads on the following structural details are not exceeded:

- floor beam span tables (pages 3 and 10);
- garage door headers (pages 4 and 11);
- window and door headers (pages 5 and 12);
- uniform load tables (pages 6 to 9 and 13 to 16);
- connection details (page 18); and
- multiple member connections (page 19).

iii) Engineering Required

For structural applications beyond the scope/limitations of the above-referenced Murphy Company publication or when required by the AHJ, the drawings or related documents must bear the authorized seal of a professional engineer skilled in wood design and licensed to practice under the appropriate provincial or territorial legislation.

Installations beyond the scope/limitations stated in Sections (i) and (ii) imply, but are not limited to, the following:

- higher loads/longer spans than the manufacturer's pre-engineered details;
- concentrated loads;
- areas of high wind or high seismicity;
- design of supporting members/columns when the total beam/header load exceeds the NBC 2005 pre-engineered beam/lintel tables; and
- design of supporting foundation footings when the total load exceeds the NBC 2005 pre-engineered floor/roof joist tables.

The engineer must design in accordance with CAN/CSA-O86 and may use as a guide the “Engineering Guide for Wood Frame Construction,” published by the Canadian Wood Council.

The specified strengths for the product must not exceed the values set forth in Table 4.1.1.1. (See Figure 1 for veneer orientation.)

Nail spacing for the product shall conform to Table 4.1.1.3. Basic nail, bolt and lag screw capacities shall be as shown in Table 4.1.1.2.

The ends of all “Murphy LVL” members used as joists, rafters and beams must be restrained to prevent rollover. This is normally achieved by attaching a diaphragm sheathing to the top or to the compression edge, and to an end wall or shear transfer panel capable of transferring a minimum unfactored uniform load of 730 N/m or the required shear forces due to wind or seismic conditions. Blocking or cross-bracing with equivalent strength may also be used.

The compression edges of all “Murphy LVL” members used as joists, rafters and beams must be laterally supported at least every 610 mm, except where design is done in accordance with CAN/CSA-O86.

iv) Engineering Support Provided by Manufacturer

The Murphy Company may provide engineering services in conjunction with its product specification and offers the following support contact number: 1-541-459-7203.

This product must be identified with the phrase “CCMC 13507-R” along the side of the product. This CCMC number is only valid when it appears in conjunction with the certification mark of APA-The Engineered Wood Association.

4. Technical Evidence

CCMC's Technical Guide for “Murphy LVL” sets out the nature of the technical evidence required by CCMC to enable it to evaluate a product as an acceptable or alternative solution in compliance with the NBC 2005. The Report Holder has submitted documentation for CCMC's evaluation. Testing was conducted at independent laboratories recognized by CCMC. The corresponding test results for “Murphy LVL” are summarized below.

4.1 NBC 2005 Compliance Data for “Murphy LVL” on which CCMC Based its Opinion in Section 1

4.1.1 Design Requirements

Table 4.1.1.1 “Murphy LVL” specified strengths (MPa)⁽¹⁾⁽²⁾⁽³⁾

Grade	Bending Strength, $f_b^{(4)}$		Tensile Strength Parallel to Grain, $f_t^{(5)}$	Compressive Strength Parallel to Grain, f_c	Compressive Strength Perpendicular to Grain, f_{cp}		Horizontal Shear Strength, f_v		MOE	
	Beam	Plank			Beam	Plank	Beam	Plank	Beam	Plank
2250Fb-1.5E	28.67	28.03	13.85	25.86	9.41	5.65	3.65	1.92	10 340	9 650
3100Fb-2.0E	39.50	37.76	21.55	35.21	9.41	6.90	3.72	1.92	13 790	13 790

Notes to Table 4.1.1.1:

(1) Specified design stresses are for standard term load duration and may be adjusted (with the exception of modulus of elasticity) using load duration factors in accordance with CSA O86-09.

(2) Specified design stresses apply to product installation conditions of use that are dry, well ventilated and covered. Dry conditions are where the moisture content of the solid-sawn lumber is 15% or less.

(3) Beam = load parallel to glueline; Plank = load perpendicular to glueline.

(4) The specified bending strength, f_b , is based on a standard depth of 305 mm. For other depths, multiply the beam's f_b by $(305/d)^{0.18}$, where d = depth in mm. For depths less than 64 mm, the factor for the 64-mm depth must be used.

(5) The specified tensile strength, f_t , is based on a standard length of 6096 mm. For other lengths, multiply f_t by $(6096/l)^{0.11}$, where l = length in mm. For lengths less than 914 mm, use the value adjusted to the 914-mm length.

Table 4.1.1.2 Equivalent specific gravity for “Murphy LVL” fastener design⁽¹⁾⁽²⁾

Grade	Equivalent Specific Gravity					
	Nails				Bolts	
	Withdrawal Load		Lateral Load		Lateral Load	
	Installed in Edge	Installed in Face	Installed in Edge	Installed in Face	Installed in Face	
					Parallel to Grain	Perpendicular to Grain
All	0.49	0.50	0.50	0.50	0.50	0.50

Notes to Table 4.1.1.2:

(1) Fastener values determined using the equivalent specific gravities in this table are for normal load duration and shall be permitted to be adjusted using the load duration factors in accordance with CSA O86-09.

(2) When loaded parallel and perpendicular to the grain, the bolt edge distance shall be a minimum of four times the bolt diameter.

Table 4.1.1.3 Nail spacing for “Murphy LVL” fastener design⁽¹⁾

Thickness (t), mm	Orientation	Fastener ⁽²⁾⁽³⁾	Minimum End Distance, mm	Minimum Nail Spacing, mm	
				Single Row	Multiple Rows ⁽⁴⁾⁽⁵⁾
$32 \leq t < 38$	Edge ⁽⁶⁾	64 mm & smaller	64	102	-
		76 mm & 83 mm	64	102	-
		89 mm	89	127	-
	Face ⁽⁷⁾	64 mm & smaller	38	76	76
		76 mm & 83 mm	38	76	76
		89 mm	38	127	127
$t \geq 38$	Edge ⁽⁶⁾	64 mm & smaller	64	76	102
		76 mm & 83 mm	89 ⁽⁸⁾	102	127
		89 mm	89	127	152 ⁽⁹⁾
	Face ⁽⁷⁾	64 mm & smaller	38	76	76
		76 mm & 83 mm	38	76	76
		89 mm	38	127	127

Notes to Table 4.1.1.3:

- (1) Edge distance shall be sufficient to prevent splitting.
- (2) 83-mm sinkers may be spaced the same as an 83-mm common wire nail.
- (3) Fastener sizes and closest on-centre spacing not specifically described above are beyond the scope of this report.
- (4) Multiple rows in the edge orientation must be spaced 13 mm or more from each other and offset one-half of the tabulated minimum nail spacing.
- (5) Multiple rows must be equally spaced from the centreline of the narrow face axis.
- (6) Nail penetration for edge nailing shall not exceed 51 mm for 89-mm nails (common or box) and 64 mm for 76-mm and 83-mm nails (common or box).
- (7) Tabulated closest on-centre spacing for face orientation is applicable to nails that are installed in rows parallel to the grain (length) of the LVL. For nails installed in rows perpendicular to the direction of the grain (width/depth) of the LVL, the closest on-centre spacing for face orientation shall be sufficient to prevent splitting of the LVL.
- (8) Minimum end distance may be reduced to 64 mm for single row nailing.
- (9) Minimum nail spacing may be reduced to 127 mm when the LVL is 44 mm or thicker.

Report Holder: Murphy Engineered Wood Division
412 West Central
Sutherlin, OR 97479
U.S.A.
Tel: 541-459-4545
Fax: 541-459-4546

Plant(s): Sutherlin, OR, U.S.A.

This Report is issued by the Canadian Construction Materials Centre, a program of the Institute for Research in Construction at the National Research Council of Canada. The Report must be read in the context of the entire CCMC Registry of Product Evaluations, including, without limitation, the introduction therein which sets out important information concerning the interpretation and use of CCMC Evaluation Reports.

Readers must confirm that the Report is current and has not been withdrawn or superseded by a later issue. Please refer to <http://www.nrc-cnrc.gc.ca/eng/services/irc/ccmc.html>, or contact the Canadian Construction Materials Centre, Institute for Research in Construction, National Research Council of Canada, 1200 Montreal Road, Ottawa, Ontario, K1A 0R6. Telephone (613) 993-6189. Fax (613) 952-0268.

NRC has evaluated the material, product, system or service described herein only for those characteristics stated herein. The information and opinions in this Report are directed to those who have the appropriate degree of experience to use and apply its contents. This Report is provided without representation, warranty, or guarantee of any kind, expressed, or implied, and the National Research Council of Canada (NRC) provides no endorsement for any evaluated material, product, system or service described herein. NRC accepts no responsibility whatsoever arising in any way from any and all use and reliance on the information contained in this Report. NRC is not undertaking to render professional or other services on behalf of any person or entity nor to perform any duty owed by any person or entity to another person or entity.

APPENDIX A

The design values obtained from testing to ASTM D 5456-07, "Evaluation of Structural Composite Lumber Products," as specified in CSA O86-09, "Engineering Design in Wood," are summarized below.

Table A1. Additional test information for “Murphy LVL”

Property	Test Information
Bending	Specimens were tested in edgewise and flatwise bending to establish the characteristic value. Data from quality control (QC) tests were used to establish the applicable coefficient of variation, CV_w , and the reliability normalization factor from CAN/CSA-O86-09 was used to determine the specified strength.
Shear	Specimens were tested in edgewise and flatwise shear to establish the characteristic value. Data from quality control (QC) tests were used to establish the applicable coefficient of variation, CV_w , and the reliability normalization factor from CAN/CSA-O86-09 was used to determine the specified strength.
Compression parallel to grain	Specimens were tested in compression parallel to grain to establish the characteristic value. Data from quality control (QC) tests were used to establish the applicable coefficient of variation, CV_w , and the reliability normalization factor from CAN/CSA-O86-09 was used to determine the specified strength.
Compression perpendicular to grain	Specimens were tested in compression perpendicular to grain to establish the characteristic value. The characteristic value was multiplied by 1.09 to establish the specified strength in accordance with CAN/CSA-O86-09.
Tension parallel to grain	Specimens were tested in tension to establish the characteristic value. Data from quality control (QC) tests were used to establish the applicable coefficient of variation, CV_w , and the reliability normalization factor from CAN/CSA-O86-09 was used to determine the specified strength.
Nail withdrawal	Nail withdrawal values were established following ASTM D 1761, “Methods for Mechanical Fasteners in Wood,” for an 8d common nail having a 31.75-mm penetration. Specimens were tested and equivalent species capacity was determined in accordance with ASTM D 5456-07, A2.4.
Nail bearing	Dowel bearing strength was determined as per ASTM D 5764-97a(2007), “Method for Evaluating Dowel-Bearing Strength of Wood and Wood-Based Products,” using 10d common nails with a nominal diameter of 3.76 mm and a lead hole diameter of 2.77 mm. Specimens were tested and the mean bearing capacity was used to establish the equivalent species capacity as per ASTM D 5456-07, A2.5.
Bolt bearing	Bolt bearing capacity was determined as per ASTM D 5764-97a (2007) using 12.5-mm- and 19.0-mm-diameter bolts.
Creep and recovery	Creep testing was conducted in accordance with the creep and recovery test described in ASTM 5456-07. The specimens met the acceptance criteria of ASTM D 6815.
Adhesive	The adhesives comply with CSA O112.6-M1977, "Phenol and Phenol-Resorcinol Resin Adhesives for Wood (High-Temperature Curing)." The two adhesives used are (i) from Georgia-Pacific Resins, LLC, family of GP 800A55 (CCMC 13321-L); and (ii) from Hexion Specialty Chemicals, Inc., family of Cascophen 84204 (CCMC 13019-L).

