



International Beams Inc.  
418 rue St. Dizier  
Montreal, Quebec H2Y 3P8

Phone: (866) 457-4043

## Technical Bulletin (TB-LVL-3)

**Subject: IB LVL Ledger Fastening**

February 2011

This technical bulletin is intended for use with International Beams Inc. products and offers general guidelines for topics that may not be covered in our literature. Appropriateness of details for a specific project should be evaluated by a qualified designer. This technical bulletin may be periodically updated. Check [internationalbeams.com](http://internationalbeams.com) to ensure that you have the most recent version.

International Beams LVL (laminated veneer lumber) typically comes in 1 ¾" thicknesses and is suitable for use as ledgers to support floor (or roof) framing. For example, IB LVL may be used to support an intermediate floor at balloon-framed walls, or it may be used to support floor framing when poured concrete foundation walls extend above the floor level.

Table 1 includes Simpson SDS screws which have been specifically tested by the manufacturer for installation into the narrow face (1 ½" thick edge) of 2x dimensional lumber. There is a reduced capacity for this type of installation (see Simpson letter L-SDSNARROWFACE, dated January 14, 2011). Other types of fasteners may split the wall stud and may not be suitable.

Table 2 includes an assembly at the floor level where the full Simpson SDS screw capacity is achieved for wood with an equivalent specific gravity for fasteners of 0.50 (Douglas Fir-Larch, or Southern Pine). Table 2 also includes capacities for IB LVL ledgers at concrete foundation walls.

# (TB-LVL-3) IB LVL LEDGER FASTENING



INTERNATIONAL BEAMS  
FEBRUARY 2011

**Table 1: IB LVL Ledgers at Balloon-framed Wood Wall Studs**

Tie-in Joist Spans Limited by IB LVL Ledger Fastening Requirements (U.S., ASD)

<p><b>IB LVL Material Properties<sup>2</sup></b></p> <p>2.0 x 10<sup>6</sup> psi E (Young's modulus)</p> <p>3100 psi F<sub>b</sub> (allowable bending stress)</p> <p>0.5 (equivalent specific gravity for fasteners)</p>	<p><b>Design Loads<sup>1</sup></b></p> <p>40 psf live load</p> <p>15 psf dead load</p>
--	--

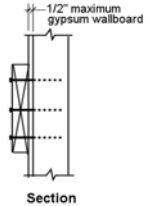
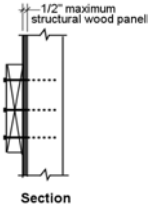
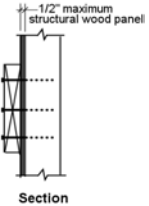
Fastener Type	Simpson SDS screw SDS25500-5.00, 5" long				Simpson SDS screw SDS25500-5.00, 5" long				Simpson SDS screw SDS25500-5.00, 5" long			
Assembly	maximum 1/2" <b>gypsum wall board</b> between IB LVL ledger and 2xSPF wood wall stud <b>[SG = 0.42]</b>  Section				maximum 1/2" <b>PLYWOOD or OSB</b> structural wood panel sheathing between IB LVL ledger and 2xSPF wood wall stud <b>[SG = 0.42]</b>  Section				maximum 1/2" <b>OSB</b> structural wood panel sheathing between IB LVL ledger and 2xDFL wood wall stud <b>[SG = 0.50]</b>  Section			
<b>Two</b> Rows of Fasteners Between Each Joist (7 1/4" to 9 1/2" LVL)	Maximum joist length based on indicated joist spacing <sup>4</sup>				Maximum joist length based on indicated joist spacing <sup>4</sup>				Maximum joist length based on indicated joist spacing <sup>4</sup>			
	12" o.c.	16" o.c.	19.2" o.c.	24" o.c.	12" o.c.	16" o.c.	19.2" o.c.	24" o.c.	12" o.c.	16" o.c.	19.2" o.c.	24" o.c.
<b>Three</b> Rows of Fasteners Between Each Joist (9 1/4" to 14" LVL)	Maximum joist length based on indicated joist spacing				Maximum joist length based on indicated joist spacing				Maximum joist length based on indicated joist spacing <sup>4</sup>			
	12" o.c.	16" o.c.	19.2" o.c.	24" o.c.	12" o.c.	16" o.c.	19.2" o.c.	24" o.c.	12" o.c.	16" o.c.	19.2" o.c.	24" o.c.
<b>Four</b> Rows of Fasteners Between Each Joist (16" to 24" LVL)	Maximum joist length based on indicated joist spacing				Maximum joist length based on indicated joist spacing				Maximum joist length based on indicated joist spacing <sup>4</sup>			
	12" o.c.	16" o.c.	19.2" o.c.	24" o.c.	12" o.c.	16" o.c.	19.2" o.c.	24" o.c.	12" o.c.	16" o.c.	19.2" o.c.	24" o.c.
	17'-5"	13'-1"	10'-11"	8'-9"	27'-8"	20'-9"	17'-3"	13'-10"	36'-4"	27'-3"	22'-9"	18'-2"

Notes:

- Tables are based on NDS-2005 (National Design Specification for Wood Construction) allowable stress design, and AWC-TR12 General Dowel Equations for Calculating Lateral Connection Values. Table values are for normal load duration ( $C_D = 1.00$ ). Adjustments shall be made for other load durations and conditions in accordance with NDS.
- Material properties may be found in the following code evaluation reports:  
 IB LVL: ICC-ES ESR-2913, issued July 1, 2009  
 Simpson SDS Screws: ICC-ES ESR-2236, reissued January 1, 2011  
 Additional information for Simpson SDS screws may be found in Simpson technical bulleting L-SDSNARROWFACE, dated January 14, 2011.  
 All pieces of structural wood panel must be nailed at maximum 6" o.c. per building code requirements if table ledger capacities are used.
- Tabulated joist spans are for ledger fastening requirements only. The building designer shall independently verify the structural adequacy of the joist itself.
- Observe the following fastener location requirements for Simpson SDS screws in the IB LVL and the lumber wall stud:  
 4 inch minimum end distance (both LVL and wall stud)  
 3 inch minimum spacing between rows (both LVL and wall stud)  
 1 1/2" edge distance (for LVL)  
 3/4 inch edge distance (centered at 2x wall stud)

# (TB-LVL-3) IB LVL LEDGER FASTENING

## Table 2: IB LVL Ledgers at Wood-framed and Concrete Foundation Walls

Tie-in Joist Spans Limited by IB LVL Ledger Fastening Requirements (U.S., ASD)

<b>IB LVL Material Properties<sup>2</sup></b>	<b>Design Loads<sup>1</sup></b>
2.0 x 10 <sup>6</sup> psi E (Young's modulus)	40 psf live load
3100 psi F <sub>b</sub> (allowable bending stress)	15 psf dead load
0.5 (equivalent specific gravity for fasteners)	

**INTERNATIONAL BEAMS**  
FEBRUARY 2011

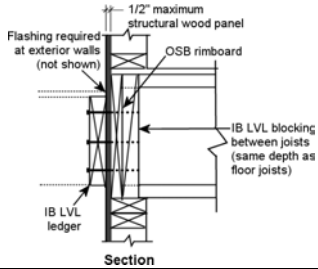
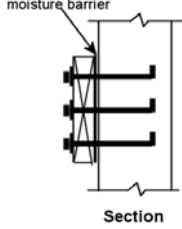
Fastener Type	Simpson SDS screw SDS25500-5.00, 5" long	1/2" diameter bolt 6" embedment in poured concrete
Assembly	maximum 1/2" OSB structural wood panel sheathing between IB LVL ledger and OSB rimboard <b>+ IB LVL blocking</b> <b>[SG = 0.50]</b> 	no gap between IB LVL ledger and concrete wall 
<b>Two Rows of Fasteners Between Each Joist</b> (7 1/4" to 9 1/2" LVL)	Maximum joist length based on indicated joist spacing <sup>4</sup>	Maximum joist length based on indicated joist spacing <sup>4</sup>
	12" o.c.    16" o.c.    19.2" o.c.    24" o.c. 24'-9"    18'-7"    15'-5"    12'-4"	12" o.c.    16" o.c.    19.2" o.c.    24" o.c. 29'-1"    21'-10"    18'-2"    14'-7"
<b>Three Rows of Fasteners Between Each Joist</b> (9 1/4" to 14" LVL)	Maximum joist length based on indicated joist spacing	Maximum joist length based on indicated joist spacing
	12" o.c.    16" o.c.    19.2" o.c.    24" o.c. 37'-1"    27'-10"    23'-2"    18'-7"	12" o.c.    16" o.c.    19.2" o.c.    24" o.c. 43'-8"    32'-9"    27'-3"    21'-10"
<b>Four Rows of Fasteners Between Each Joist</b> (16" to 24" LVL)	Maximum joist length based on indicated joist spacing	Maximum joist length based on indicated joist spacing
	12" o.c.    16" o.c.    19.2" o.c.    24" o.c. 49'-5"    37'-1"    30'-11"    24'-9"	12" o.c.    16" o.c.    19.2" o.c.    24" o.c. 58'-2"    43'-8"    36'-4"    29'-1"

**Notes:**

- Tables are based on NDS-2005 (National Design Specification for Wood Construction) allowable stress design, and AWC-TR12 General Dowel Equations for Calculating Lateral Connection Values. Table values are for normal load duration ( $C_D = 1.00$ ). Adjustments shall be made for other load durations and conditions in accordance with NDS.
- Material properties may be found in the following code evaluation reports:  
 IB LVL: ICC-ES ESR-2913, issued July 1, 2009  
 Simpson SDS Screws: ICC-ES ESR-2236, reissued January 1, 2011  
 Additional information for Simpson SDS screws may be found in Simpson technical bulleting L-SDSNARROWFACE, dated January 14, 2011.  
 All pieces of structural wood panel must be nailed at maximum 6" o.c. per building code requirements if table ledger capacities are used.
- Tabulated joist spans are for ledger fastening requirements only. The building designer shall independently verify the structural adequacy of the joist itself.
- Observe the following fastener location requirements for Simpson SDS screws in the IB LVL and the lumber wall stud:  
 4 inch minimum end distance (both LVL and wall stud)  
 3 inch minimum spacing between rows (both LVL and wall stud)  
 1 1/2" edge distance (for LVL)  
 3/4 inch edge distance (centered at 2x wall stud)
- Table values for bolts in poured concrete are for NO gap between the LVL and the concrete. Epoxied bolts may be used if all manufacturer instructions are followed, but no increase in capacity is permitted. Bolt location requirements for the IB LVL ledger itself are as follows:  
 4 inch minimum end distance  
 3 inch minimum spacing between rows  
 2" edge distance

These LVL-controlled bolt locations must be maintained. This may require reduction of capacity for bolt spacing or edge distance in the concrete based on ACI-318 criteria or bolt/epoxy manufacturer's requirements. A moisture barrier is required between the LVL and exterior concrete/masonry foundation wall as required by building codes.