



International Beams Inc.
418 rue St. Dizier
Montreal, Quebec H2Y 3P8

Phone: (866) 457-4043

Technical Bulletin (TB-IJ-5)

Subject: IB I-joist Reinforcement at Offset Interior Bearings

August 2010

This technical bulletin is intended for use with International Beams Inc. products and offers general guidelines for topics that may not be covered in our literature. Appropriateness of details for a specific project should be evaluated by a qualified designer. This technical bulletin may be periodically updated. Check internationalbeams.com to ensure that you have the most recent version.

Detail 1g in International Beams I-joist Design Manual illustrates a typical condition where interior bearing walls align with an interior bearing wall or beam directly below. It is best to have the bearings align from level-to-level because it makes it easier to accomplish continuity of load path. However, on occasion, we are requested to evaluate conditions where the interior bearings do not align.

When the misalignment of interior bearings is a foot or less, the limiting factor of the design of a wood joist is nearly always shear or interior reaction. A solid-sawn lumber joist is evaluated with a graduated formula whereby the effect of shear is diminished as the misalignment decreases from a distance equal to the depth of the member. The old rule-of-thumb where shear was ignored totally for this amount of misalignment is no longer accepted for lumber, and also does not apply to pre-fabricated wood I-joists.

IB I-joists are typically designed with IB beam analysis software where the misaligned interior bearings are accounted for in the analysis. In some cases, this condition works without reinforcing. In other cases, the joist spacing can be reduced to avoid the need for reinforcing. If the analysis shows that the I-joist will still be overstressed under full design load, sometimes reinforcement can be added to increase the capacity. The detail which follows illustrates how this may be accomplished.

(TB-IJ-5) IB I-joist Reinforcement at Offset Interior Bearing

August 2010

Design / installation considerations:

- Longer joist spans are more likely to be overstressed simply because they may already be close to the maximum interior reaction limit even with no wall load applied above.
- Vertical load. When interior bearings align, I-joist blocking panels or squash blocks transfer vertical load directly to the bearing below. When the interior bearings do not align, the vertical load from the bearing wall above must pass thru the I-joist itself. This is why reinforcement is sometimes required for the I-joist when bearings are misaligned.
- Lateral load. I-joist blocking over the interior bearing is also required for global lateral stability. You may not think about lateral stability when interior bearings are aligned because you have already been required to install I-joist blocking for vertical load. However, when the interior bearings do not align you still need the I-joist blocking directly above the interior bearing.

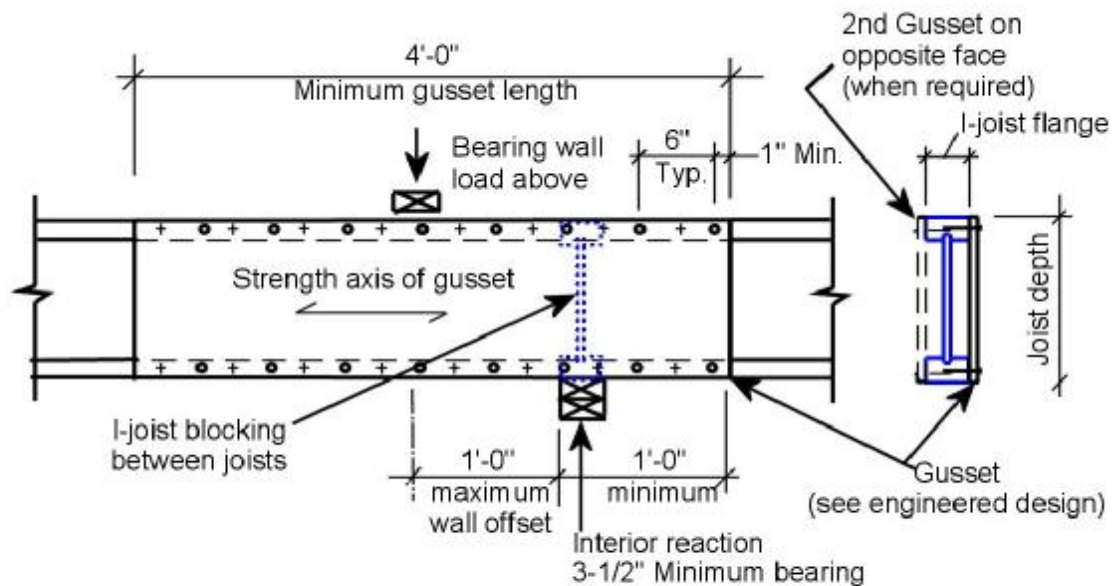

IB I-joist Reinforcement at Offset Interior Bearings

- Designates nail from near face.
- + Designates nail staggered from far face (when 2nd gusset is used).