



International Beams Inc.  
418 rue St. Dizier  
Montreal, Quebec H2Y 3P8

Phone: (866) 457-4043

## Technical Bulletin (TB-IJ-4)

**Subject: Brick-to-Grade Cantilever for IB I-joists**

August 2010

This technical bulletin is intended for use with International Beams Inc. products and offers general guidelines for topics that may not be covered in our literature. Appropriateness of details for a specific project should be evaluated by a qualified designer. This technical bulletin may be periodically updated. Check [internationalbeams.com](http://internationalbeams.com) to ensure that you have the most recent version.

A popular architectural feature in some regions is a brick-to-grade detail (sometimes called brick cantilever, or brick ledge). Brick veneer is used below grade and the brick stops at the bottom of the floor joists. The floor joists cantilever over the brick veneer and support the exterior wall above. By definition, brick veneer is not intended to support vertical load, only its own self-weight. Construction gaps directly above the brick veneer, closed off with flexible sealants, prevent the I-joists from bearing on the brick veneer.

The details which follow illustrate some typical brick cantilever installations using International Beams I-joists.

Design / installation considerations:

- Vertical load. These illustrations apply to lightly loaded walls at the end of the cantilever. Unreinforced I-joists are shown. The I-joist bearing capacity may be increased up to the maximum end reaction by adding web stiffeners. International Beams software may be used to determine if additional reinforcement is required.
- Lateral load. In a typical non-cantilevered end bearing, lateral stability is provided by the OSB rimboard which is attached to the floor diaphragm and also toenailed to the bearing wall plate directly below. When a cantilever is present, this lateral load path is missing. For longer cantilevers, the lateral load path is restored by installing I-joist blocking directly over the bearing. For short



## **(TB-IJ-4) Brick-to-Grade Cantilever for IB I-joists**

August 2010

cantilevers up to 5", the 2x8 flat blocking shown between I-joists may be used for lateral load transfer instead of the I-joist blocking. This method has the additional attraction of facilitating installation of insulation in the cantilever.

- Increased nailing or other mechanical fastening may be specified by the building designer to resist lateral loads for high wind or seismic zones.
- The perpendicular I-joist blocking (sometimes referred to as ladder blocking) illustrated in details B and C will create uplift at the backspan at the girder connection. This detail limits the uplift to a maximum of 250 pounds per joist unfactored (350 pounds factored). The wall at the end of the cantilever is assumed to be a gable wall or lightly loaded wall. The building designer is cautioned to limit the uplift at the girder. Increased loading at the end of the cantilever will increase uplift at the backspan of the I-joist blocking and can create an upward bow in the girder. Longer girders may have significant tie-down requirements at the ends of the girder.
- The length of the perpendicular I-joist blocking illustrated in details B and C should be no more than the span-rating of the subfloor. This will avoid APA (American Plywood Association) requirements for additional blocking support for the subfloor when the subfloor span-rating is exceeded. Although the orientation of the subfloor may be changed at the perpendicular I-joist blocking, this would create a continuous joint in the subfloor at the girder, and the benefits of staggering the subfloor joints would be lost.

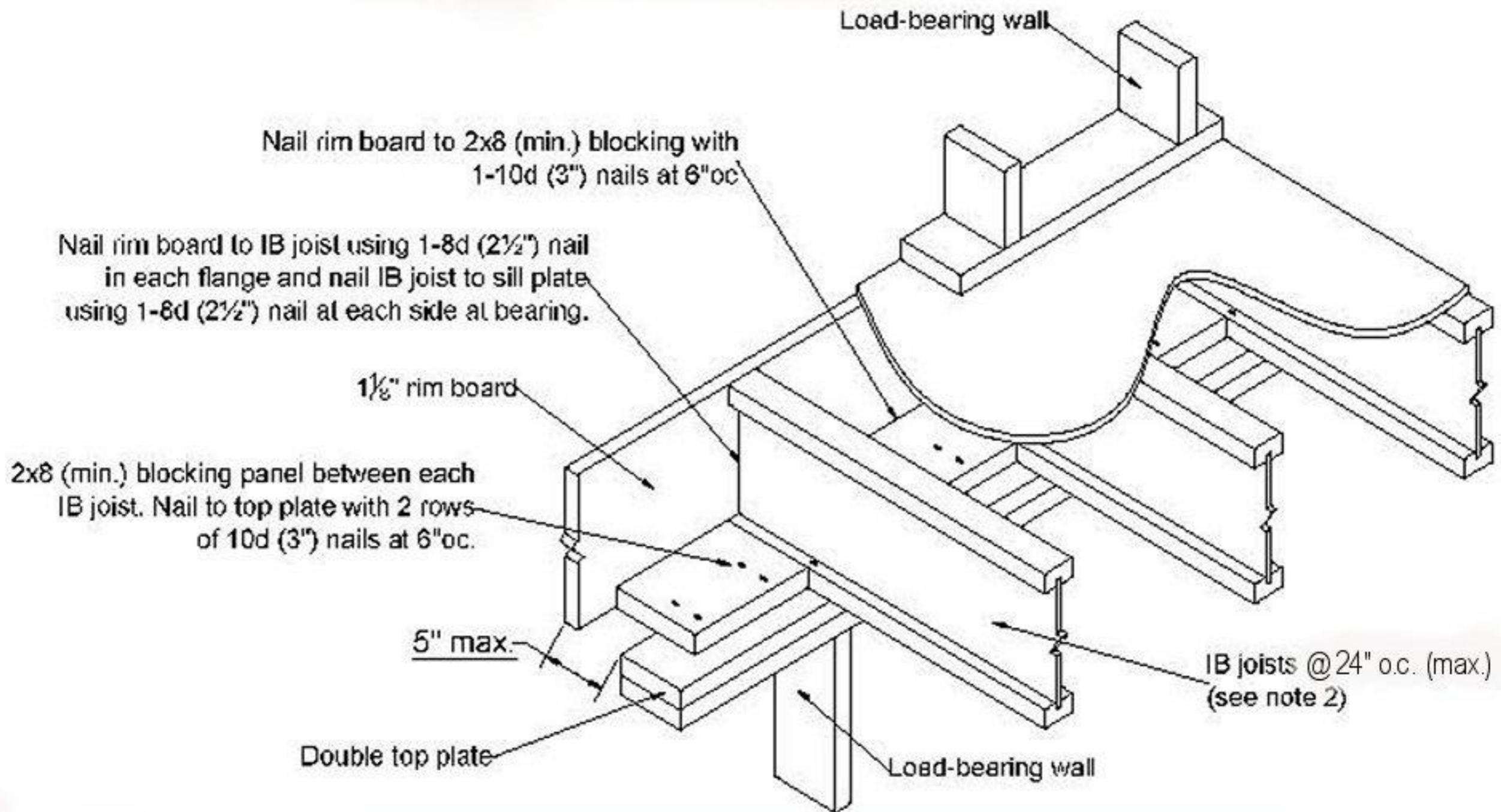

Notes:

1. Detail applicable to residential applications only.
2. IB I-joists shall be properly designed to carry the cantilever loads. Reinforcement may be required.
3. Indicated nails are box nails or equivalent:  
 8d, minimum 0.113" diameter x 2 1/2" long  
 10d, minimum 0.128" diameter x 3" long
4. Full-depth blocking panels may be installed directly over the wall instead of the flat 2x8 blocking shown.
5. Detail shown above is adequate for end stability of the IB I-joist itself. Additional lateral resistance may be required in high wind and/or seismic load areas. Consult with the project design professional of record.

**(TB-IJ-4) BRICK-TO-GRADE CANTILEVER**  
**DETAIL A, TYPICAL JOIST CONDITION**



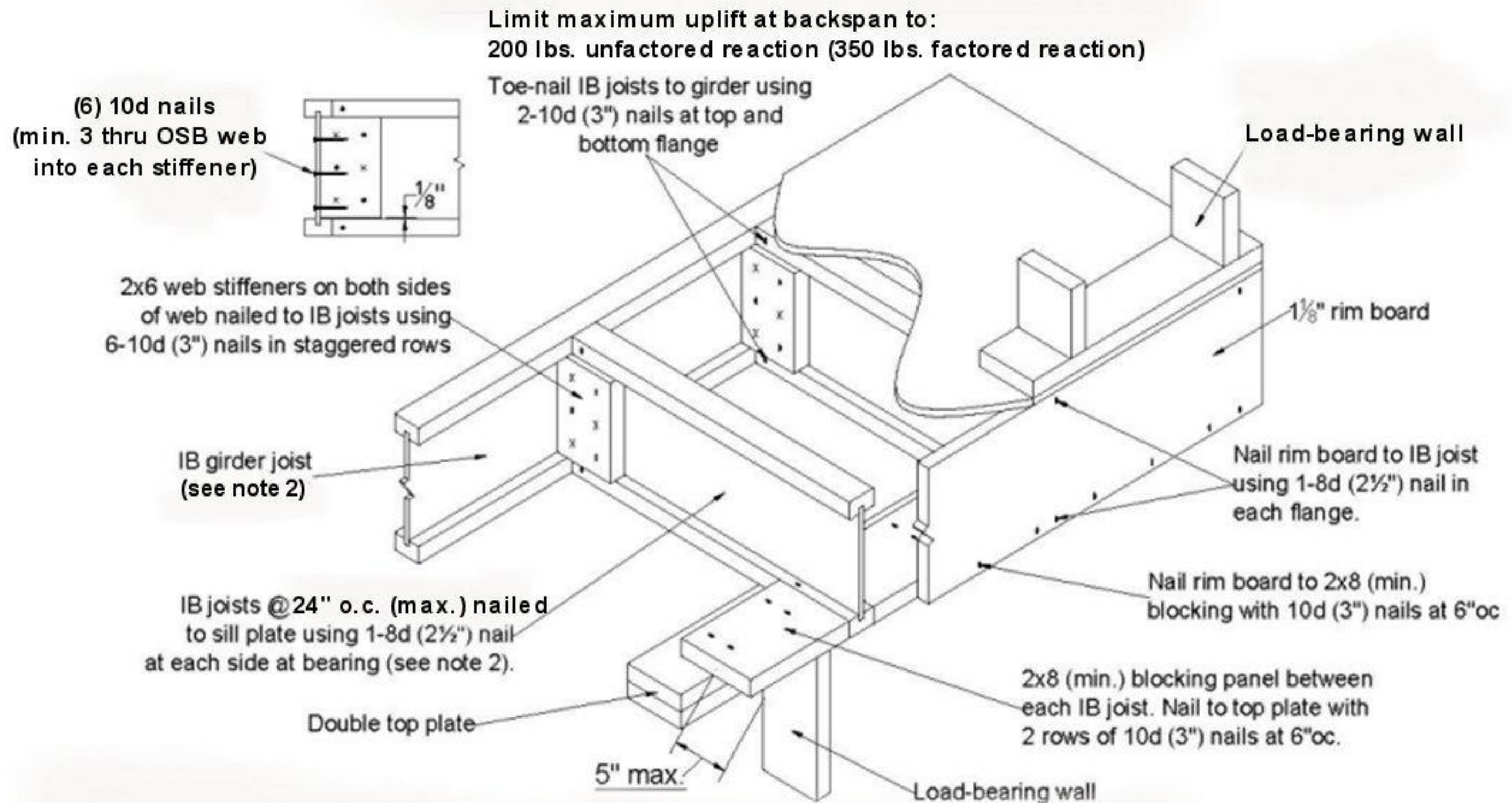

Notes:

1. Detail applicable to residential applications only.
2. IB I-joists shall be properly designed to carry the cantilever loads. Reinforcement may be required. Maximum uplift at backspan shall be limited to 200 lbs. unfactored reaction (or 350 lbs. factored reaction). IB girder shall be properly designed to carry the IB I-joists. Double I-joist and filler blocking may be required.
3. Indicated nails are box nails or equivalent:
  - 8d, minimum 0.113" diameter x 2 1/2" long
  - 10d, minimum 0.128" diameter x 3" long
4. Full-depth blocking panels may be installed directly over the wall instead of the flat 2x8 blocking shown.
5. Detail shown above is adequate for end stability of the IB I-joist itself. Additional lateral resistance may be required in high wind and/or seismic load areas. Consult with the project design professional of record.

**(TB-IJ-4) BRICK-TO-GRADE CANTILEVER**  
**DETAIL B, PERPENDICULAR I-JOIST BLOCKING CONDITION**



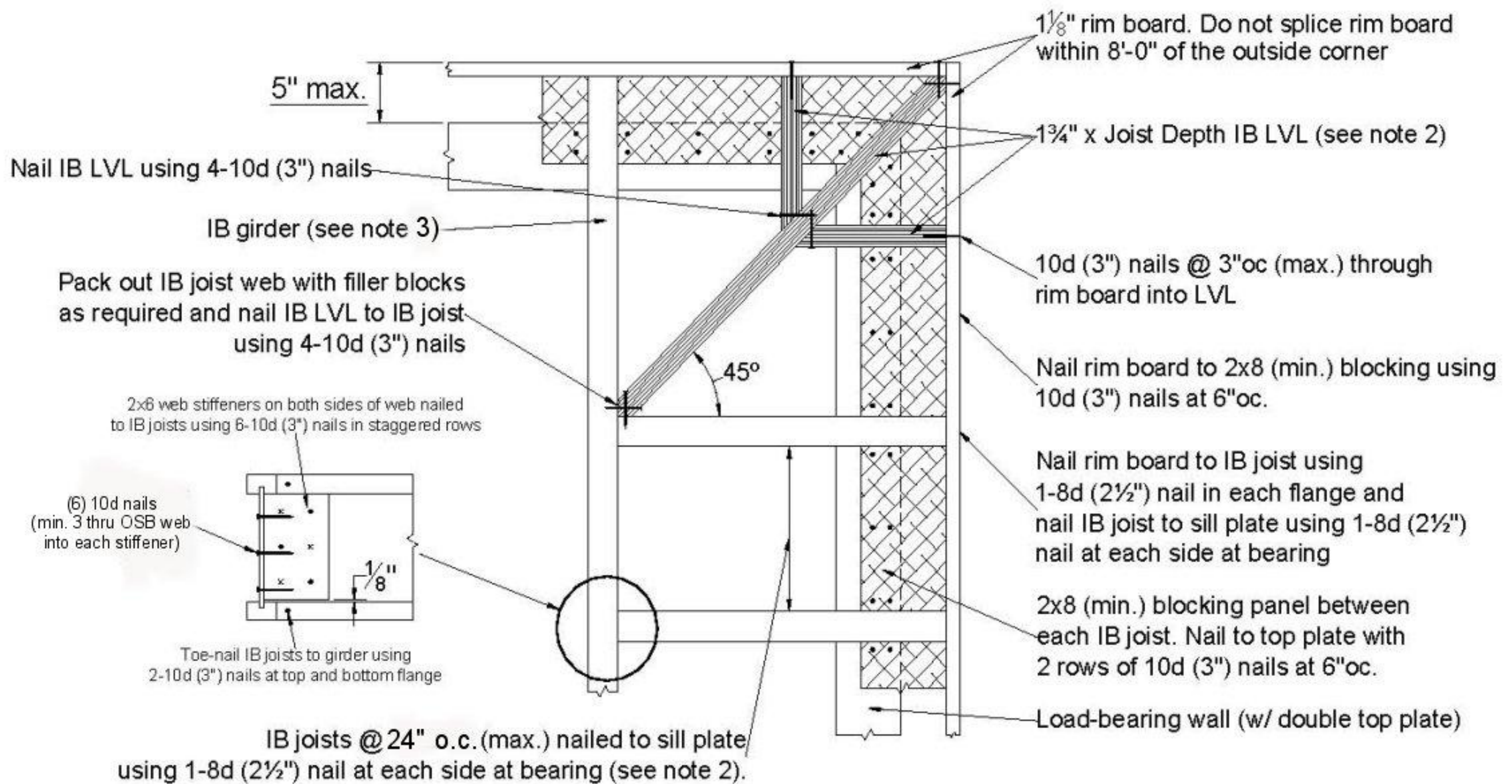

Notes:

1. Detail applicable to residential applications only.
2. IB I-joists and LVL shall be properly designed to carry the cantilever loads. Reinforcement may be required. Maximum uplift at backspan shall be limited to 200 lbs. unfactored reaction (or 350 lbs. factored reaction). IB girder shall be properly designed to carry the IB I-joists and LVL. Double I-joist and filler blocking may be required.
3. Indicated nails are box nails or equivalent:
  - 8d, minimum 0.113" diameter x 2 1/2" long
  - 10d, minimum 0.128" diameter x 3" long
4. Full-depth blocking panels may be installed directly over the wall instead of the flat 2x8 blocking shown.
5. Detail shown above is adequate for end stability of the IB I-joist itself. Additional lateral resistance may be required in high wind and/or seismic load areas. Consult with the project design professional of record.

**(TB-IJ-4) BRICK-TO-GRADE CANTILEVER**  
**DETAIL C, CORNER CONDITION**

