



International Beams Inc.
418 rue St. Dizier
Montreal, Quebec H2Y 3P8

Phone: (866) 457-4043

Technical Bulletin (TB-IJ-1)

Subject: Heading Off of Cut IB I-joists

August 2010

This technical bulletin is intended for use with International Beams Inc. products and offers general guidelines for topics that may not be covered in our literature. Appropriateness of details for a specific project should be evaluated by a qualified designer. This technical bulletin may be periodically updated. Check internationalbeams.com to ensure that you have the most recent version.

Nearly everyone has encountered this condition. You have carefully planned the location of plumbing and electrical drops (maybe even indicated locations on your layout) but somehow the I-joist is located right where the plumbing or wiring needs to go. One possible way to work around these obstructions is to “head off” the I-joists. Depending on the location of the obstruction, one or possibly two headers will be needed. The details which follow illustrate how this might be done.

Design / installation considerations:

- The cut I-joist, header, and supporting I-joists all need to be evaluated, but will still be acceptable in most cases. As long as the I-joists are designed for the new loading condition, this is a perfectly acceptable method. These conditions may be checked on International Beams sizing software.
- Remember to temporarily shore the floor before cutting all the way through the damaged I-joists. Leave the shoring in place until all connections have been completed and inspected.
- The span-rating of the subfloor should be maintained. Install wood blocking, if necessary, to reduce the subfloor span at areas between headers and between headers and walls. Additional wood blocking may be required around openings, particularly toilet drops, where screwed attachment of PVC pipe flanges is needed.
- Sometimes heading off an I-joist is not the best solution. International Beams has engineers on staff who can assist you with alternate solutions.

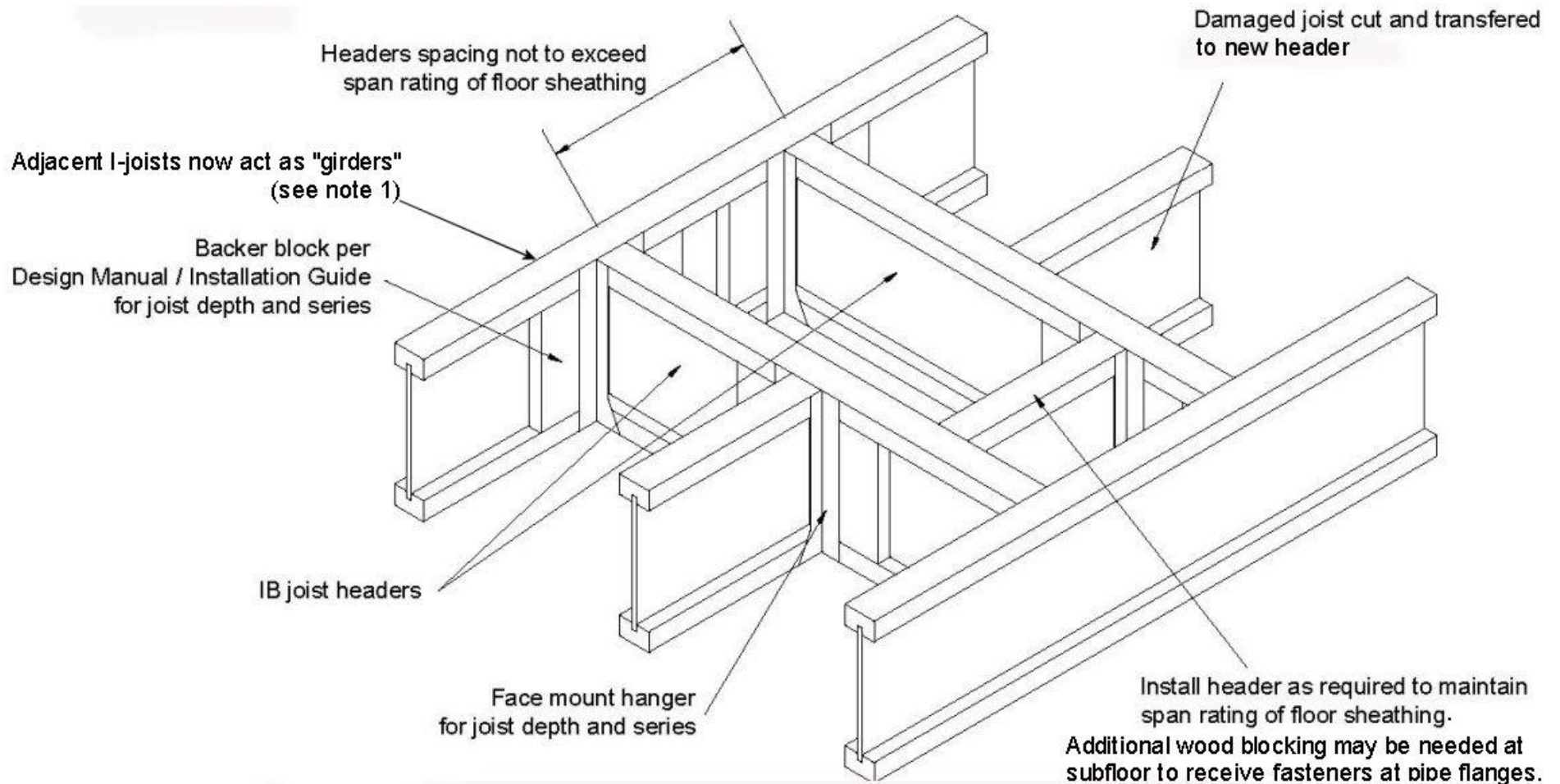

Notes:

1. Adjacent I-joists ("girders") and new headers shall be properly designed to support the additional loads. Cut I-joist shall be reviewed for possible uplift reactions (multi-span conditions).
2. Apply construction adhesive in hanger seats and at all wood-to-wood contact surfaces. Adhesive shall meet APA specification AFG-01 or ASSTM D3498.
3. Observe all hanger manufacturer installation recommendations. I-joists require web stiffeners at face-mount hangers if the hanger flanges do not extend to the top of the I-joist.
4. Refer to the IB Design Manual and Installation Guide for construction details and guidelines.

(TB-IJ-1) HEADING OFF OF CUT IB I-JOISTS **DETAIL A (TWO HEADERS)**

(Page 2 of 3)



INTERNATIONAL BEAMS
AUG. 2010

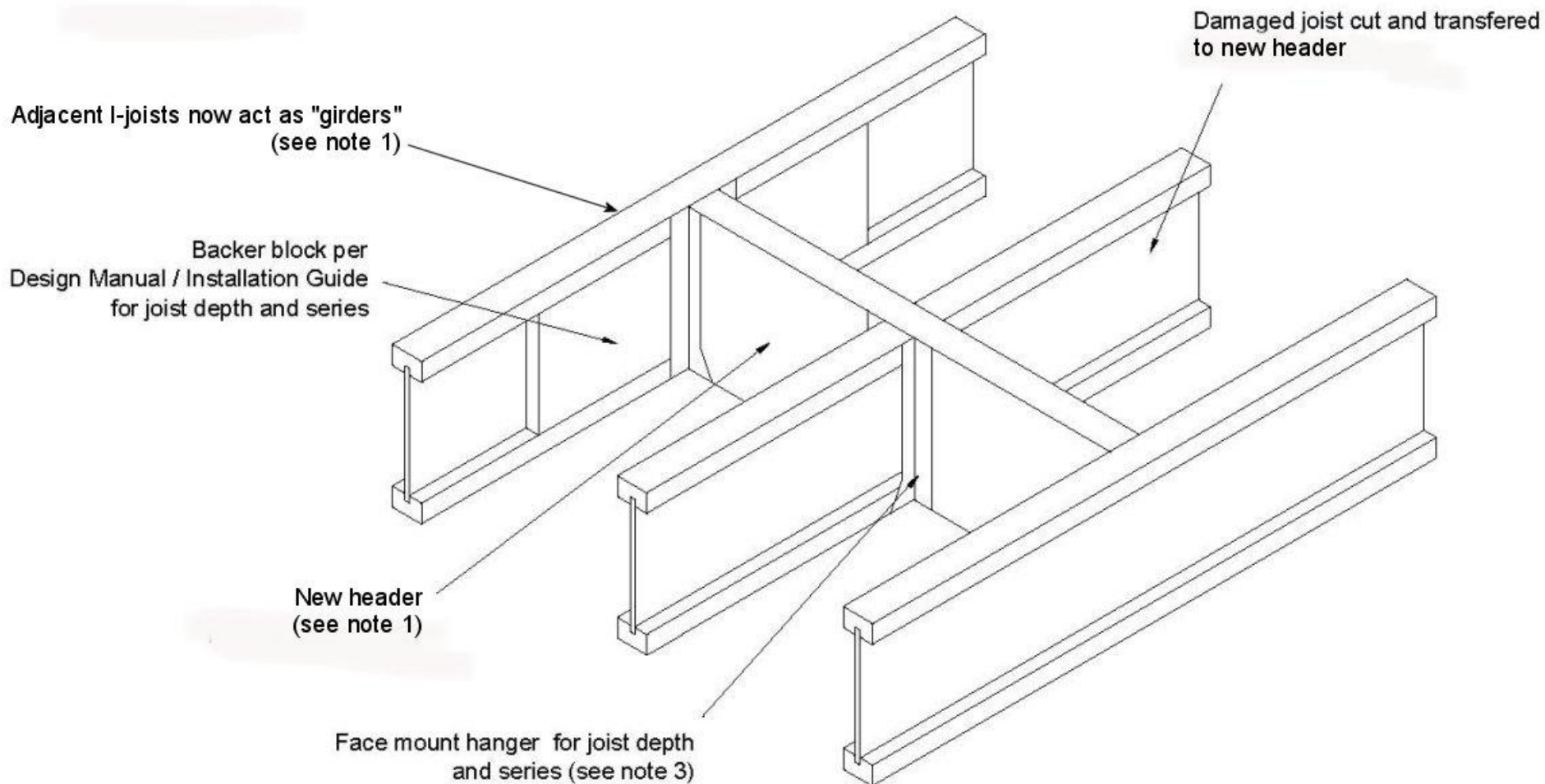

Notes:

1. Adjacent I-joists ("girders") and new headers shall be properly designed to support the additional loads. Cut I-joist shall be reviewed for possible uplift reactions (multi-span conditions).
2. Apply construction adhesive in hanger seats and at all wood-to-wood contact surfaces. Adhesive shall meet APA specification AFG-01 or ASSTM D3498.
3. Observe all hanger manufacturer installation recommendations. I-joists require web stiffeners at face-mount hangers if the hanger flanges do not extend to the top of the I-joist.
4. Refer to the IB Design Manual and Installation Guide for construction details and guidelines.

(TB-IJ-1) HEADING OFF OF CUT IB I-JOISTS
DETAIL B (SINGLE HEADER)

(Page 3 of 3)



INTERNATIONAL BEAMS
AUG. 2010